

# PAMKUU

## User Manual V1.0

July, 18th, 2017

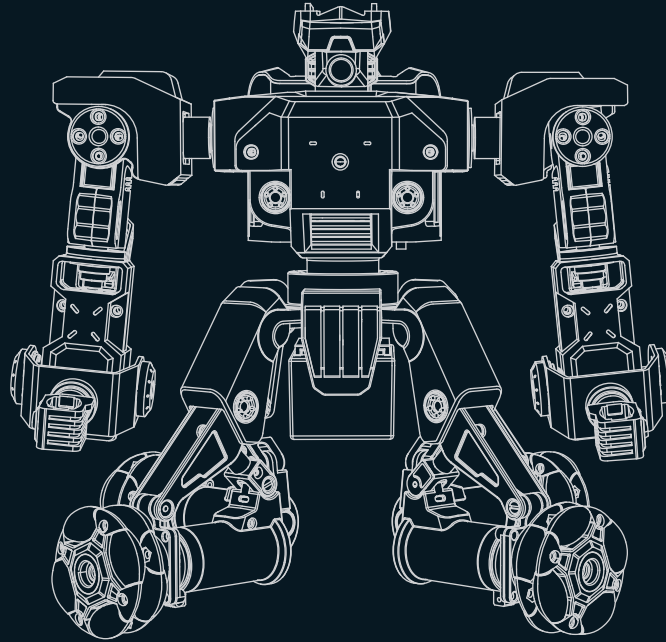

<http://pamkuu.walkera.com>

# Contents

<b>1.0 Product Introduction</b>	03
<b>2.0 Product Parameters</b>	04
<b>3.0 Preparations for operation</b>	
3.1 Packing list	05
3.2 Download and install PAMKUU software	05
3.3 Charging	05
3.4 Battery installation	06
3.5 Sword and haudguh mounting	06
3.6 Connection method	06
<b>4.0 APP Activation</b>	07
<b>5.0 Operating Instructions</b>	
5.1 Basic controls: Control Interface	08
5.2 Basic Operation: Menu Settings	08
5.3 Basic operations: skill pool interface	09
5.4 Basic operations: skill setting interface	09
5.5 Basic operations: Add skill interface	10
<b>6.0 Game Rules</b>	11
<b>7.0 Online Upgrade</b>	12
<b>8.0 Attentions</b>	
8.1 Non-warranty conditions	13
8.2 Battery	13
<b>9.0 Robot Maintenance</b>	14

# 1.0 Product Introduction

- The PAMKUU edutainment contest robot aims to provide such different game plays as fighting and racing by utilizing robot joint motion module, electronic scoring system, and APP controls.
- Chassis, which is composed of 4 omnidirectional wheels and metal skeletons running through omnidirectional wheels, helps achieve swerving and advancing in an all-around and multi-directional manner.
- Players operate PAMKUU robot and control the movement and customize the skill movements to fight through the APP.

- |                             |
|-----------------------------|
| 1. Head                     |
| 2. Front Chest              |
| 3. Shoulders                |
| 4. Arms                     |
| 5. Hands                    |
| 6. Legs                     |
| 7. Omnidirectional Wheel    |
| 8. Back                     |
| 9. Power Switch             |
| 10. Battery                 |
| 11. Handgun connection port |

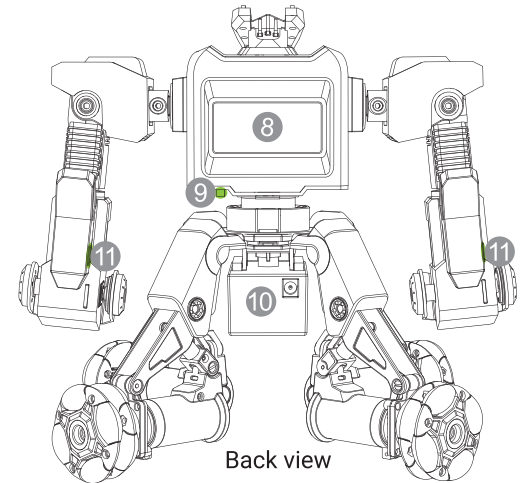
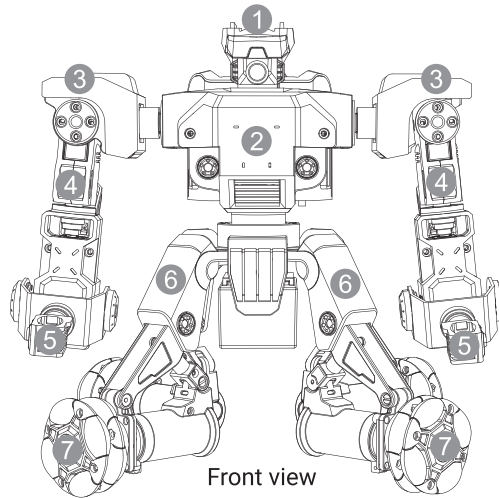

- \* 1) Prior to using PAMKUU robot, you are kindly requested to visit official website (<http://pamkuu.walkera.com>) to watch the video tutorial and carefully read the User Manual, so as to avoid property loss and personal injuries caused by misoperation.
- 2) PAMKUU robots are suitable for players that are at least 14 years old.

## 2.0 Product Parameters

Size	254 x 254 x 228mm
Weight (exl. weapon)	About 1660g
Degree of freedom	9 joints, angles can be adjusted from 130°~155° (based on different joints), and chassis subject to omnidirectional control at 12 dimensions.
DC power supply	7.4V 1500mAh Li-Po battery
Control Mode	APP control
APP system	IOS / Android
Light Effect	Eyes subject to dual-color LED, chest scoring sensor subject to LED light
Protection design	Battery overcharging protection, high temperature protection, joint locked-rotor current protection mechanism, voltage detection
Internal Sensor	Approach & collision sensor / infrared pulse sensor
Connection mode	High-speed WiFi connection
Charger	8.4V==1A



## 3.0 Preparations for operation

### 3.1 Packing list

Check all the following items in your package. If any of them is missing, please contact walkera or your local dealer.

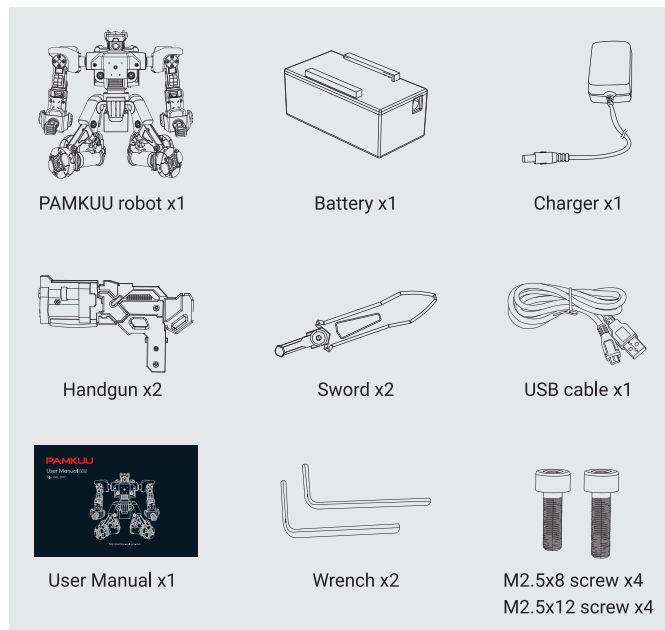

### 3.2 Download and install PAMKUU software

Software supports **iOS 9.0 / Android 5.0** and later versions.

For IOS system, please go to APP Store to download and install it.



For Android system, go to official website (<http://pamkuu.walkera.com>) or Google Play to download and install it.



### 3.3 Charging

- 1) Connect the charger to the power source(100~240V 50/60HZ).
- 2) Insert charger plug (DC 8.4V) into the charging socket.
- 3) Red light indicates charging status while green light indicates completion of charging, it takes about 110min to get the robot fully charged.

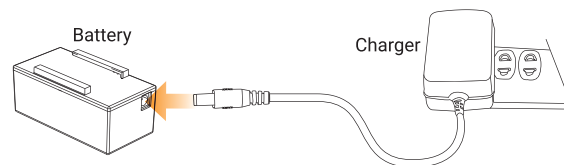

**Note:** While charging, batteries must be placed in a dry, ventilated place away from heat source and inflammables or explosives.

### 3.4 Battery installation

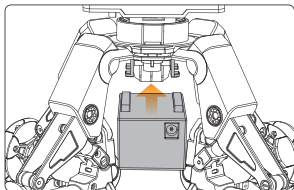

1. Properly insert batteries from back to front

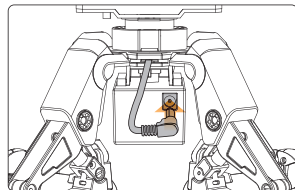

2. Connect power cable.

### 3.5 Sword and handgun mounting

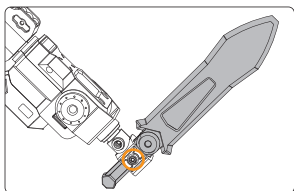

1. Mount sword and tighten screw (M2.5x8).

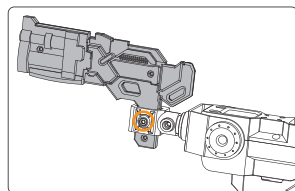

2. Mount handgun and tighten screw (M2.5x12).

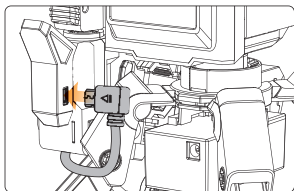

3. Connect handgun cable.

### 3.6 Connection method

PAMKUU connects to mobile devices directly through Wi-Fi. The connection steps are as follows:

- 1) PAMKUU will automatically give off WiFi signal one minute after it is activated.
- 2) Enter the WiFi setting interface of the mobile device.
- 3) On the WiFi setting interface of a mobile device, initial display of PAMKUU WiFi is "PAMKUU\_xxxxxx", where "xxxxxx" is a unique number corresponding to every set of machine.
- 4) Click to select it and enter password (default password: 12345678).
- 5) Just open APP.



## 4.0 APP Activation



1. Tap the icon on the mobile phone screen.

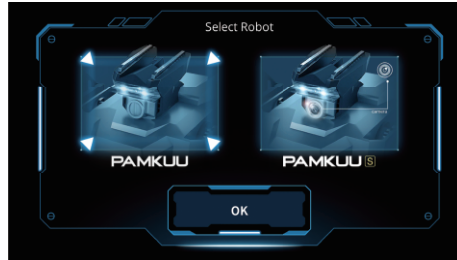

2. Select "PAMKUU" and click "OK".



3. Click "START".

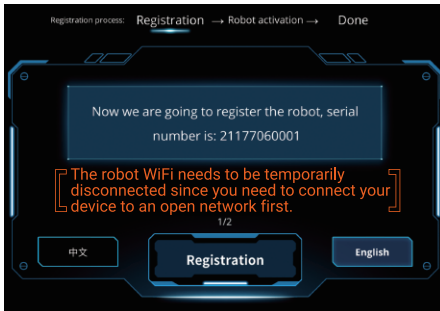

4. The dialog box will automatically pop out if the robot is unactivated. Disconnect your device from the robot WiFi, then connect the device to an open network and click "Registration"

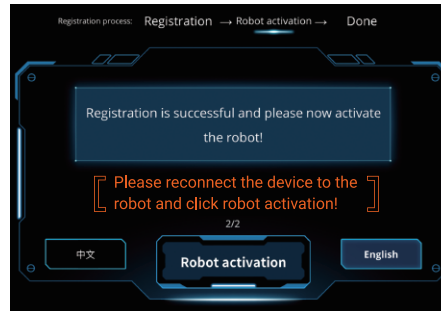

5. Connect the robot WiFi (PAMKUU\_XXXXXX) and click "Robot activation"

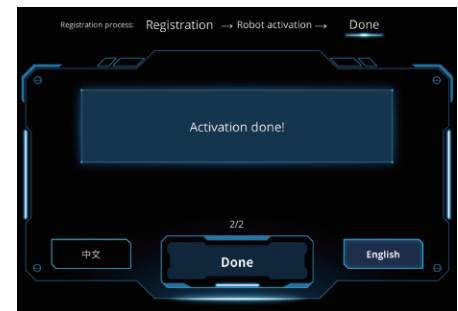

6. Click "Done" to enter the control interface. Please follow the operation steps again should you fail to activate.

## 5.0 Operating Instructions

### 5.1 Basic controls: Control Interface



1. Electric quantity: in percentage, to decrease from right to left.
2. Hit Point: to decrease from right to left.
3. WiFi connection status button:  
Two states: blue (successful connection), red (connection loss)  
When the button is red, the connection tutorial will automatically show up.  
When it is blue, click it to open or close the interface icon explanation.
4. Set button: click it to pop up [Setting Menu].
5. Skill interface: to display 4 melee attack skills and a ranged weapon button.
6. Rotate button: to control clockwise or anticlockwise rotation of the robot.
7. Two sets of preset skills are switchable.
8. Quickly reset the robot posture: quickly restore the robot to the default posture.
9. Directional joystick.

### 5.2 Basic Operation: Menu Settings



1. Skill pool: click it to enter the skill pool interface.
2. Audio & Vibrate: click it to ON or OFF.
3. Robot Selection: Click to select the robot model.
4. Language Selection: to select Chinese or English.
5. Boot & Preview: click it to enter the Boot & Preview interface.
6. About: Display of company and software related information and the Fight Tutorial.

### 5.3 Basic operations: skill pool interface



1. Back button: back to previous interface.
2. Skills List: click it to edit this skill, scroll up to view more skill icons.
3. Skill settings: click it to enter the skill setting interface.
4. Add skill: click it to enter the skill edit interface.

### 5.4 Basic operations: skill setting interface



1. Skills list: skill demonstration.
2. No. of preset skill sets: Two sets of preset skills marked with 1 & 2 respectively.
3. Skill setting operation: click any skill in the list of skills on the left side, and then click one of the preset skills on the right side to change.
4. Save button: save the newly set skill.
5. Cancel button: not modify.

## 5.5 Basic operations: Add skill interface

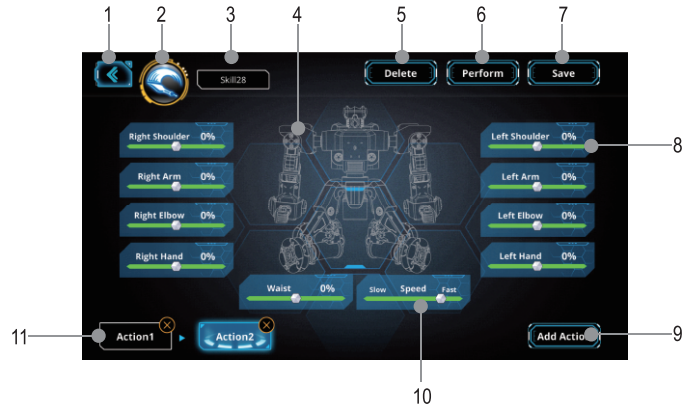

1. Back button: back to previous interface.
2. Skill icon: click it to select skill icon
3. Skill name: click it to edit its name, better less than 6 characters.
4. Servo part indication: When adjusting servos corresponding to each part of the robot, the corresponding part is highlighted.
5. Delete or Revert default: there will be a delete button on the newly added skills, click it to delete the skill. There will be a revert default button, click it to revert factory defaults for the skill, and click save to complete.
6. Perform: click it to perform the skill once.
7. Save: click it to save a new skill.
8. Servo adjusting slider
9. Add action: click it to add a new action, click "Action" to modify action parameter.
10. Speed adjustment: to adjust speed.
11. Action: Click icon (⊗) to delete this action, click "Action" to modify parameters, robot can act accordingly.

## 6.0 Game Rules

At least 2 sets of PAMKUU robot are needed to battle against each other. When PAMKUU's sensor is attacked by a weapon, a certain HP shall be lost. A PAMKUU robot is judged to lose the battle when its HP reduced to zero.

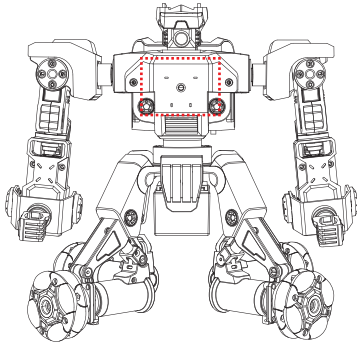

Effective attack scope of ranged weapons: front chest

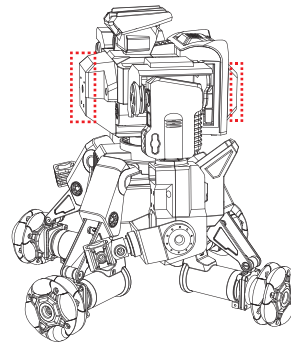

Effective attack scope of melee weapons: front chest and back

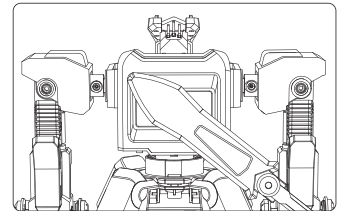
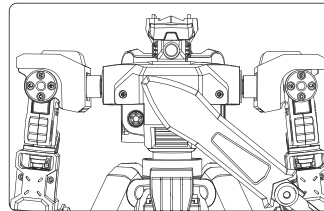
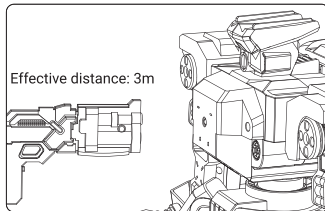

## 7.0 Online Upgrade

Online upgrade is available on official website (<http://pamkuu.walkera.com>).

- 1) Remove the PB1.7x6 screws, open decoration cover at the rear of the robot.
- 2) Connect the USB data cable to robot USB port and computer USB port.
- 3) Mount the decoration cover when the upgrade is complete.

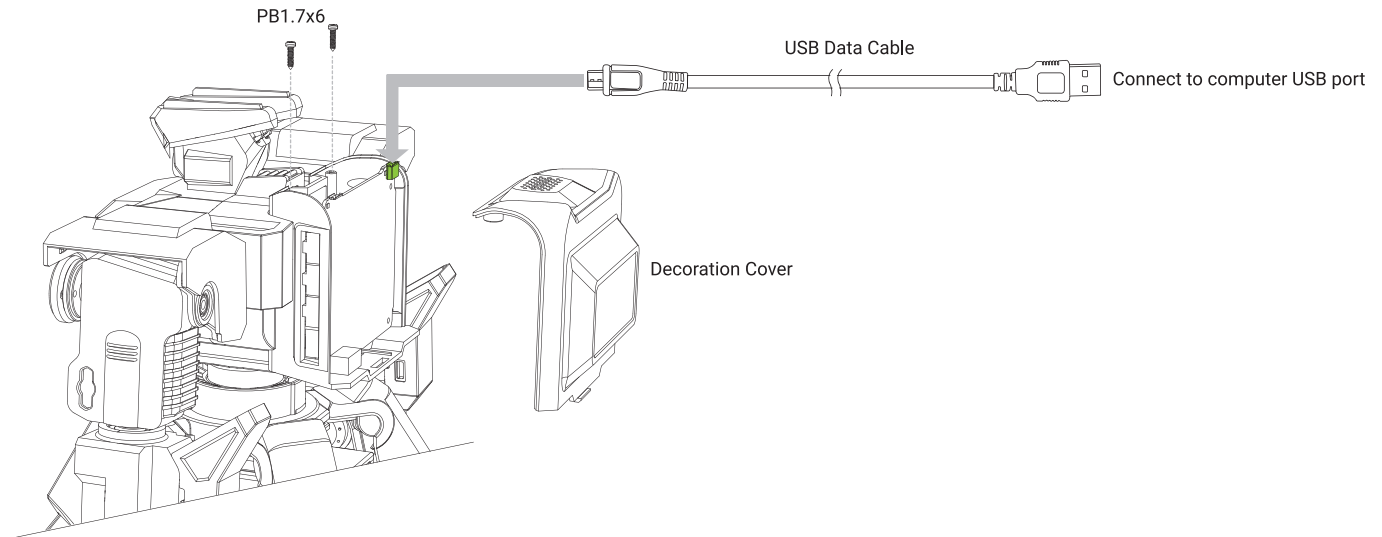



## 8.0 Attentions

### 8.1 Non-warranty conditions

- 1) Damage resulting from use of accessories not provided by Walkera;
- 2) Damage resulting from users' unauthorized refit;
- 3) Unavoidable damage (such as dropping, waterlogging, collision, electric shock and burn) resulting from improper operation or use of products;
- 4) Damage resulting from natural disaster;
- 5) Damage resulting from disassembly, maintenance by unauthorized agencies or maintenance sites.

### 8.2 Battery

- 1) Batteries must be stored in a dry, ventilated place with ambient temperature of 18-25 °C.
- 2) Repeated charging and excessive discharging must be prevented to improve batteries' service life.
- 3) Prior to long-time storage, charging maintenance must be done to batteries, i.e. charge up to 50-60% the saturated volume before storage.
- 4) Never dismantle or alter circuits, nor puncture batteries. Never place it onto inflammables or leave it unattended during charging.
- 5) Always keep charger's output voltage identical with battery voltage.
- 6) Keep the battery out of reach of children

## 9.0 Robot Maintenance

### Tips

- 1) When there are faults with your PAMKUU robot or when you need assistance, please log onto official website (<http://pamkuu.walkera.com>) to contact us, we are ready to provide you with excellent after-sale services.
- 2) If you want to repair it by yourself, be sure to consult with after-sales personnel before following the repair procedure or instructions.  
Walkera shall not be responsible for any damage caused by any unauthorized disassembly.

### Maintenance Instructions

Furious collisions are inevitable for fighting robots during the game, there will be some injuries on some parts of the robot. Players are advised to practice the operations of PAMKUU robot before a fight with other players. In the mean time, try to alternatively use melee and ranged weapons to increase the service life of the robot.



Manufacturer: Guangzhou Walkera Technology Co.,Ltd.  
Add: No.48 Wantai Rd, Taishi Industrial Park, Dongchong Town,  
Nansha Dist, Guangzhou, China.511453  
Hotline: +86 400-931-8878

---

User manual is subject to change without prior notice.  
Please go to official website (<http://pamkuu.walkera.com>) to get the latest version.

